



DIRECTIONAL LEDS



3735 SERIES Surface Mount

This compact and versatile surface-mount LED directional light is ideal for applications requiring high intensity output, low-current draw and maintenance-free operation. These auxiliary LED heads feature a clear acrylic lens optic with LEDs that illuminate in the color of your choice. Warning capability can be customized by selecting from 11 different flash patterns (via trigger wire).

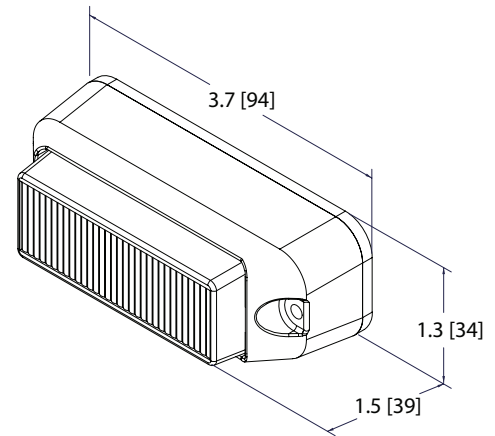

Models

PART NO.	VOLTAGE	AMPS	MOUNT
3735X	12	0.3	Surface

Replace X in part number with desired color: A=amber, B=blue, C=clear, G=green, R=red

Features and Benefits

- ABS plastic housing with encapsulated electronics
- 11 flash patterns
- Discrete units are colorless when not illuminated
- LEDs offer a long, maintenance-free service life
- Temperature Range: -22°F to +122°F (-30°C to +50°C)

Flash Patterns (11)

- Steady Burn
- Single
- Fast Single
- Double
- Fast Double
- Triple
- Quad
- Quint Hold
- Pulse8
- Constant Pulse8
- Cycle

Accessories

UNIVERSAL
A3730BKT



TRUNK
A3730TNK



DECK
A3730DCK



WINDOW
A3730WIN



LICENSE
A3730LIC

